

Manual Etalon-Based Fiber Optic Tunable Filter



(patent pending)

DATASHEET

BUY NOW



Based on a proprietary thin film cavity filter technology, we produce Fiber Optic Tunable Filters with central wavelengths of 1060nm to 2050nm. Other center wavelength can also be made. It is tunable continuously over a wide spectral range up to 100 nm with a 1nm peak bandwidth. Longer center wavelength has larger tuning range. The wavelength tuning is made by manually rotating a precise micrometer. Our unique high reliability and low insertion loss design presents a most cost-effective solution for OEM applications from fiber optic networks to fiber sensing interrogation.

The current standard configurations are in volume production thus having low cost benefit. Other wavelength is available that requires extra cost to make the filter.

Features

- 1000nm to 2400nm
- 1nm Bandwidth
- 100nm Tuning Range
- SM and PM
- <3dB loss
- Up to 5W Optical Power
- Compact and Low Cost
- Low IL and PDL

Applications

- DWDM networks
- Fiber Sensing
- ASE control
- Tunable Fiber Laser

Specifications

Parameter	Min	Typical	Max	Unit
Center Wavelength	350		2400	nm
Tuning Range [1]	-	± 30	± 50	nm
Tuning Resolution	-	0.1	-	nm
Insertion Loss [2]	1.5	2	3.5	dB
Bandwidth @-3dB	-	1	1.2	nm
Bandwidth @-20dB	-	10	-	nm
Off-Band Suppression	-	30	-	dB
PDL (SM fiber only)	-	0.15	0.35	dB
PMD (SM fiber only)	-	-	0.5	ps
Extinction Ratio (PM fiber only)	18	23	-	dB
Return Loss	40	-	-	dB
Optical Power Handling (CW)				
Standard version	-	0.5		W
High power version		10		W
Operating Temperature	0	20	60	°C
Storage Temperature	-10	-	70	°C

Note:

[1]. Longer the wavelength, larger the tuning range

[2]. Measured using a broadband light source with integration of the transmission peak. If the laser source does not matching the filter profile, extra loss can occur. Special filter can be made to match the application. Smaller the fiber core, higher the loss. Excluding connector loss

Legal notices: All product information is believed to be accurate and is subject to change without notice. Information contained herein shall legally bind Agiltron only if it is specifically incorporated into the terms and conditions of a sales agreement. Some specific combinations of options may not be available. The user assumes all risks and liability whatsoever in connection with the use of a product or its application. Agiltron, The Power to Transform and Agiltron logo are trademarks of Photonwares Corporation. © 2009, 2012 IPG Photonics Corporation. All rights reserved.

Rev 06/29/23

© Photonwares Corporation

P +1 781-935-1200

E sales@photonwares.com

W www.agiltron.com

Information contained herein is deemed to be reliable and accurate as of the issue date. Photonwares reserves the right to change the design or specifications at any time without notice. Agiltron is a registered trademark of Photonwares Corporation in the U.S. and other countries.

Manual Etalon-Based Fiber Optic Tunable Filter



(patent pending)

DATASHEET

Mechanical Dimension (mm)

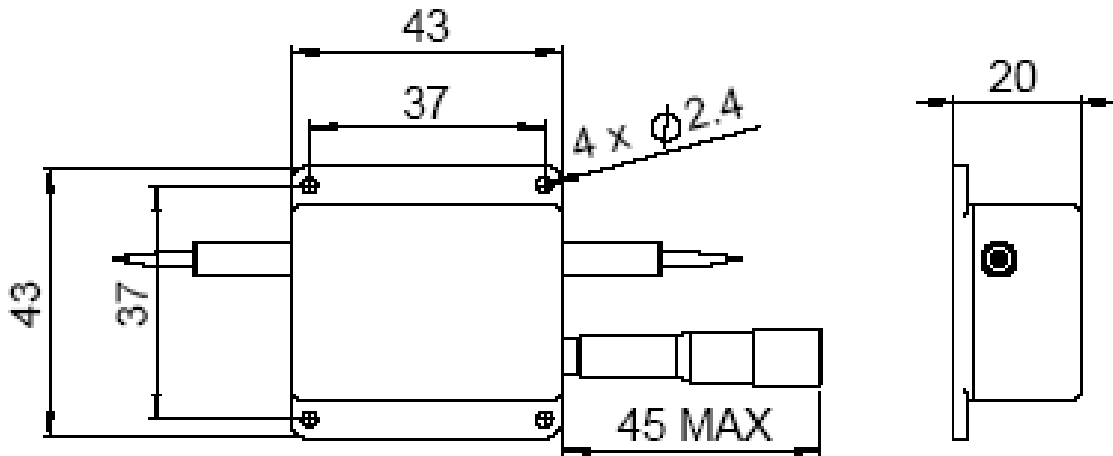

*Product dimensions may change without notice. This is sometimes required for non-standard specifications.

Typical Transmission Curve

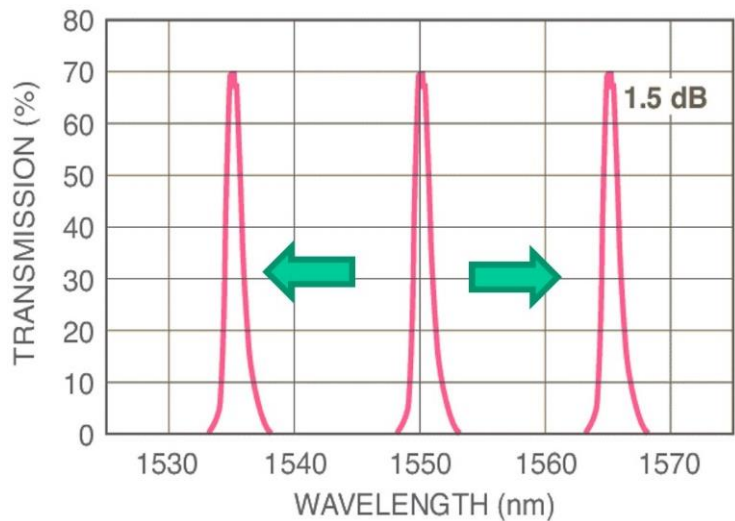
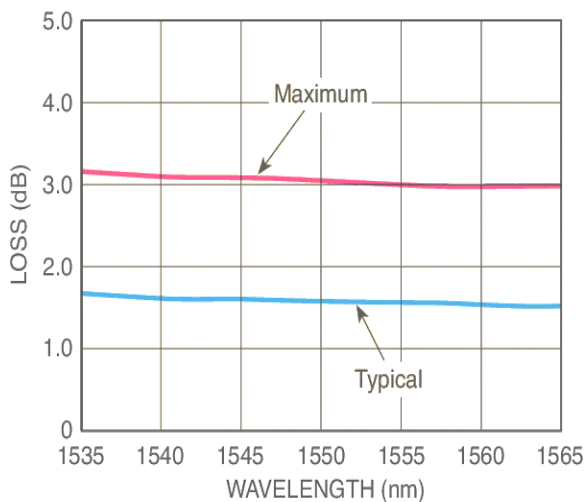

Manual Etalon-Based Fiber Optic Tunable Filter



(patent pending)

DATASHEET

Bandwidth Definition

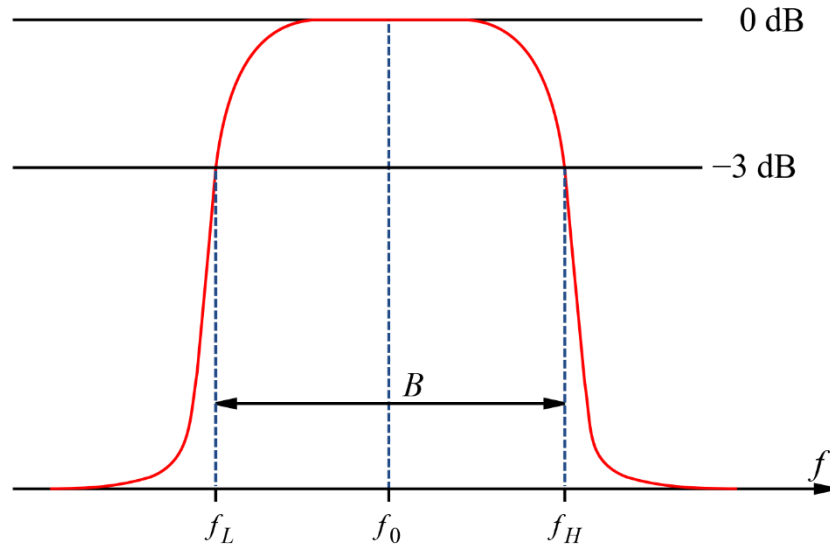

Ordering Information

Prefix	Type	Wavelength	Power	Pack	Fiber Type	Fiber Cover	Fiber Length	Connector
FOTF-		2100± 60nm = 1 2295± 55nm = K 2195± 55nm = J 2095± 55nm = I 2050± 50nm = H 2000± 50nm = 2 1960± 40nm = 4 1850± 50nm = A 1800± 50nm = G 1620± 40nm = 7 1550± 50nm = 9 1550± 40nm = 5 1480± 40nm = 8 1395± 55nm = F 1310± 40nm = 3 1230± 50nm = E 1145± 45nm = D 1130± 40nm = C 1060± 40nm = 6 1005± 45nm = B Special = 0	Standard = 1 High Power = 2	2	SMF-28 = 1 HI1060 = 2 PM980 = 3 PM1550 = 4 Special = 0	Bare fiber = 1 900um tube = 3 Special = 0	0.25m = 1 0.5m = 2 1.0 m = 3 Special = 0	None = 1 FC/PC = 2 FC/APC = 3 SC/PC = 4 SC/APC = 5 ST/PC = 6 LC = 7 Special = 0

Red Items require NRE of \$1950 to make the filter